

# User guide

IRON DOG 07

©2021

**BRUNNER**<sup>®</sup>  
*made in germany.*

## **Iron Dogs**

are cast Iron stoves made in Germany, manufactured by a family business in the 3th generation, specialized in making fireplaces. In this series all their knowledge and craftsmanship come together in an exceptional stove of an exceptional quality. Therefore also the exceptional name »IRON DOG« for exceptional people or as a gift to friends.

Winter can come; we're looking forward to it.

Welcome to the IRON DOG family.

Eggenfelden, August 2007



Ulrich Brunner

The name >>EISERNER HUND<< - >>IRON DOG<< - is a registered and protected mark. Individual models are registered as design patents.

## CONTENTS

<b>1</b>	<b>My Iron Dog.....</b>	<b>4</b>
<b>2</b>	<b>Safety guidelines.....</b>	<b>4</b>
<b>3</b>	<b>Basic principles.....</b>	<b>6</b>
<b>4</b>	<b>Firewood and heating power.....</b>	<b>8</b>
<b>5</b>	<b>Seasoning of firewood.....</b>	<b>11</b>
<b>6</b>	<b>Amount of fuel.....</b>	<b>11</b>
<b>7</b>	<b>Components.....</b>	<b>12</b>
<b>8</b>	<b>Operation.....</b>	<b>14</b>
	8.1 Lighting fire in a cold fireplace.....	16
	8.2 Stoking up in a warm fireplace.....	17
<b>9</b>	<b>Cleaning.....</b>	<b>17</b>
<b>10</b>	<b>Hint.....</b>	<b>19</b>
<b>11</b>	<b>Error search.....</b>	<b>19</b>
<b>12</b>	<b>Attention.....</b>	<b>21</b>

## IRON DOG

Please read the entire User Guide before lighting the fire for the first time. In particular, please note the safety precautions in this manual. The User Guide, as well as national or EU standards and local regulations must be observed. Your specialized enterprise and **IRON DOG** partner can give you the most current information and details.

**Please keep the User Guide for future reference!**

## **1 MY IRON DOG**

An **EISERNER HUND** is a special cast iron stove. It's a friend for life. Its life expectancy is about generations and it will do good services to its owners – therefore treat it well.

Nearly all components of the **IRON DOG** are made of solid cast iron. A special, temperature-firm color coating protects the surface. All components of this cast iron stove are manufactured and assembled in Germany with great care

## **2 SAFETY GUIDELINES**



### **Radiation range**

Do not bring inflammable materials within an 80 cm radiation range of the **IRON DOG**! Fire risk! Don't put inflammable objects on the stove top, under the cast iron stove or in between the rear of the stove and the wall behind.



## First starting-up

Up to the first reaching of the maximum operating temperature the protective paint hardens out. This can give some smelling nuisances. Provide therefore for sufficient ventilation of the installation area. Open doors and windows. Don't stay unnecessarily in the concerned area. Never use products as gasoline, white spirits or the like to start a fire!



## Burning risk

The external surfaces of the **IRON DOG** become hot, especially the window of the fire door.

Don't touch – Burning risk!

Particularly warn children for this. Keep children away from the heated **IRON DOG**.

Use safety gloves during operation.



## Ashes

Empty the ash pan only when the ashes are cold and keep them during at least 24 h in a fire resistant container. Fire risk by remaining glow! In case of fire, call the fire-brigade!



## Chimney fire

In case of a chimney fire, remove all inflammable objects from the chimney. Beware of flying sparks. Call the fire-brigade!

**Fire door**

The fire door of the **IRON DOG** may only be opened for bringing in wood or for cleaning. During use with open fire door, the stove is too heavily charged, smoke or fire can come out and glowing particles can be ejected. There is the danger of a flue gas poisoning. The fire chamber of the **IRON DOG** is also to be kept closed when the stove is not heated.



The **IRON DOG** is equipped with a firing door and a large fireplace door. Smoke escape!

Open the fireplace door only to clean the glass or reach the ash box. Do not open during heating!

Refill with wood logs only from the side firing door. The stove will be overloaded when operating with an open door. Smoke or fire can escape, or embers can be thrown out.

### **3 BASIC PRINCIPLES**

Cast iron stoves of the **IRON DOG** series function according to the principal of 'burning from above' and are heated with the intermittent burning method. The wood load degases with beautiful flames in approximately 60 - 70 minutes and produces a heating output between 5 - 9 kW/h depending on the quantity of wood (1,5 kg - 2,5 kg).

Cast iron stoves of the **IRON DOG** series are tested according to EN 13240 / EN 12815 and can be used with a closed fire door. Connecting more than one stove to a chimney is possible if the chimney is suited for this (ask the chimney sweep).

## **Air supply to the setting up area**

The **IRON DOG** can only function properly when the combustion air supply at the setting up area is sufficient. Before heating up make sure there is a sufficient supply of fresh air. In the building existing mechanisms for combustion air supply should not be changed.

## **Fuel**

Use only suitable burning wood in the indicated quantities and qualities. Too small amounts of burning wood lead to insufficient combustion quality. Too large amounts of burning wood lead to overheating and damage to the equipment. Fire risk!

## **Heat output**

The cast iron stoves of the **IRON DOG** series are designed to be used with the intermittent wood burning method; the heat output is determined by the quantity of wood used and by the distances in time between the firing operations. The right time to put on more wood has come when the wood has nearly been burned down to glow.

## **Combustion air regulation**

For a simple operation the air income is regulated with one single air control rod. Please heat with the given combustion air regulations. Insufficient combustion air leads to an increased environmental impact, bad efficiency and creosote in the stove and the chimney.

## **Heating operation**

We recommend using safety gloves during operation, since the operating elements become hot. Open the door slowly – this way no turbulences develop, which let flue gases escape.

## **Flue exhaust/heating during transitional periods**

The **IRON DOG** needs sufficient chimney draught for drawing in the combustion air and exhausting the flue gases. It diminishes with rising outside temperatures and this can lead to problems to start a fire. When outside temperatures are over 15°C, please check the chimney draught. (for example open the door and keep a burning fire lighter at the entry of the flame channel – flame and flue gases must visibly take off). In case of too little draught first light kindling and add burning wood when the draught has been created.

# **4 FIREWOOD AND HEATING POWER**

The combustion process in our devices has been optimized to enhance their performance and reduce emissions. You can support our efforts to protect our environment by respecting the following recommendations for low-emission heating: Use only dry, natural wood with a residual humidity factor below 20%, or wood briquettes according to DIN EN 17225-3.

Damp, freshly cut or improperly stored wood has a high water content, therefore does not want to burn, makes a lot of smoke and gives not much of heat. Use only firewood which has been stored for at least two years in a dry place with sufficient air circulation. Because dry wood is much more calorific, you can save on fuel costs.

For example: Dry wood has a calorific value of approx. 4 kWh/kg, freshly cut wood only 2 kWh/kg. You will need twice the amount of wood to achieve the same heating power.

	Water content g/kg wood	Calorific value kWh/kg	Consumption raised by %
very dry	100	4,5	0
stored for 2 years	200	4	15
stored for 1 year	350	3	71
freshly cut wood	500	2,1	153



Natural firewood (left) is the best fuel for fireplaces, but you can use also wood briquettes according to DIN 17225-3, Class A1, length >14 cm (5.51 in), diameter >8 cm (3.15 in) (right).



What amount of heat will I get when buying wood per weight?

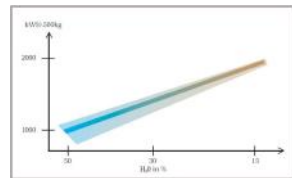

1 cubic meter freshly cut wood	Water content 50%	500 kg x 2,0 kWh/kg = 1000 kWh
1 cubic meter dried wood	Water content 30%	500 kg x 3,3 kWh/kg = 1650 kWh
1 cubic meter dry wood	Water content 15%	500 kg x 4,1 kWh/kg = 2050 kWh

What amount of heat will I get when buying wood per volume (1 cubic meter = 1 m3)?

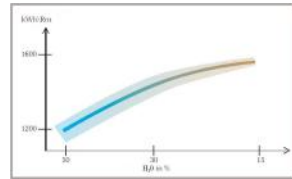

1 cubic meter freshly cut wood	Water content 50%	1286 kWh
1 cubic meter dried wood	Water content 30%	1518 kWh
1 cubic meter dry wood	Water content 15%	1550 kWh

Most suitable for use in open fireplaces are all types of hardwood, like beech or birch. Softwood species (conifers) have a closed-cell structure which is bursting during combustion, causing glowing embers to be thrown out of the fireplace. Hardwood is burning more calm and evenly.

You can control the heat radiation intensity by volume of wood and the intervals for stoking up.

Adjusting the heat by reducing the volume of combustion air is wrong! If there is not enough combustion air available, the energy contained in fire-wood cannot be completely released. At the same time, the emissions are rising due to unburned particles.

Too much of firewood or inappropriate fuel types can cause overheating and damage.

No kind of waste shall be burned in a fireplace!

***Waste on fire = Toxins in your garden!***



Never use combustible fluids, like petrol or alcohol to light a fire!

Mind the waste incineration ban!

Remember to use only the recommended fuels described in this User Guide. Unsuitable, not recommended fuels are not allowed to be burned in a fireplace.

## 5 SEASONING OF FIREWOOD

After cutting the trees, the wood should be seasoned in an open and dry place and protected from rain and snow.

The best time to cut trees is from December till February.

Firewood should be stored under a roof or in a ventilated building (shed). Do not store freshly cut wood in the cellar or in a closed area. It can't dry there.

### **Our best 3 tips**

for heating with wood to become an experience.

**1) dry wood**

**2) dry wood**



**3) dry wood**

## 6 AMOUNT OF FUEL

Heat output regulation by combustion air reduction is wrong!

By lack of combustion air the calorific capacity of the fuel can't be set free completely. At the same time the emissions increase over the unburned portions.

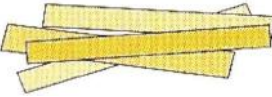
Too large amounts of fuel or unsuitable fuel can lead to excessive heating and thus to damage.

Filling weight	Log length	Log size
1,5 kg - 2,5 kg	25 cm - 48 cm	20 cm - 30 cm
for nominal heat output 1,6 kg for full heat output 2,5 kg		

## 7 COMPONENTS

### Operating elements

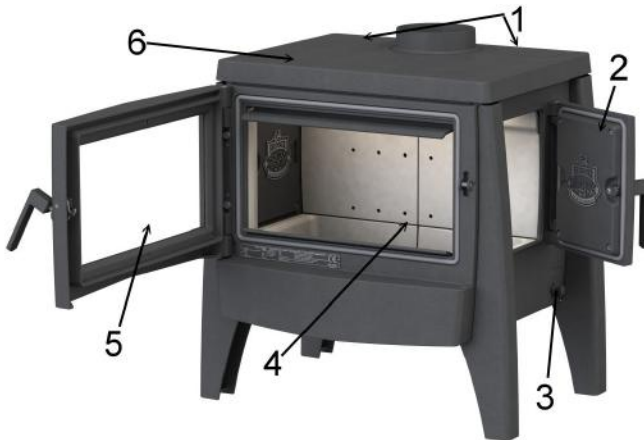

- |   |                      |   |                    |
|---|----------------------|---|--------------------|
| 1 | Inlay for cleaning   | 2 | Firing door        |
| 3 | Air control push rod | 4 | Combustion chamber |
| 5 | Stove door           | 6 | Hot plate          |

## Component parts

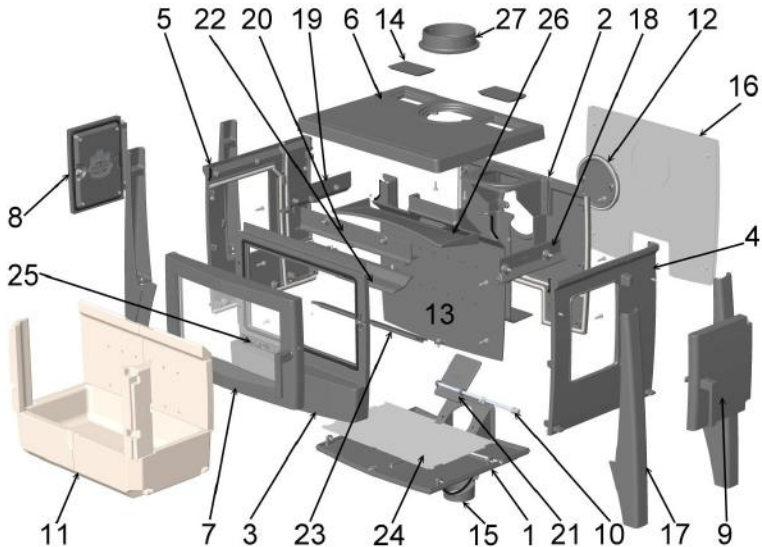

Pos.	Pcs	Designation	Art.No.:	Pos.	Pcs	Designation	Art.No.:
1	1	Base trough	K012004	2	1	Rear wall	K012071
3	1	Front	K012005	4	1	Right side wall	K012002
5	1	Left side wall	K012003	6	1	Hot plate	K012066
7	1	Door front	K012008	8	1	Door side blind	K012055-02
9	1	Door side	K012008-01	10	1	Push rod	K012037
11	1	Firebox lining	K012044	12	1	Blind cover D150	K012051
13	1	Separation wall	K012074	14	2	Cleaning plate	K012081
15	1	Air inlet nozzle D100	K012079	16	1	Radiation shield	K012082
17	4	Foot	K012017-01	18	1	Upper air duct right side	K012027
19	1	Upper air duct	K012031	20	1	Upper air duct cross-way	K012032-01
21	1	Push rod plate	K012020-01	22	1	Upper air difuser	K012038
23	1	Front inlay	K012039	24	1	Bottom plate	K012040
25	1	Identification plate ID 07	K012077	26	1	Baffle plate	K012033
27	1	Flue outlet nozzle 6"	K009152-02				

## 8 OPERATION



To prevent damage of the combustion chamber lining, the Iron Dog 07 requires the first five heating cycles with max. 2 kg capacity of wood. The max. fuel quantity of logs can be used only after the heating of the combustion chamber lining.

Start-up

Combustion air completely open  
for a fast heating up

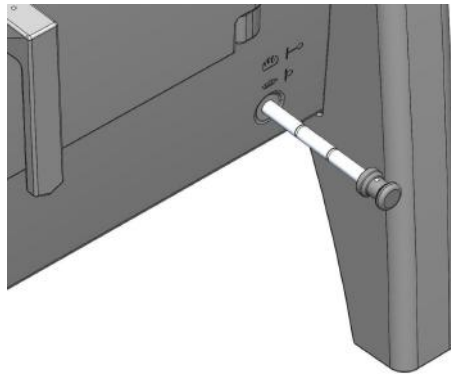

Full load output

Heating operation for a full heat  
output

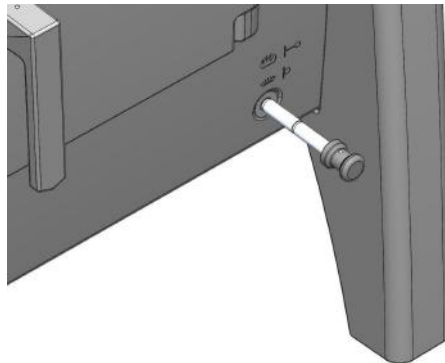

Nominal heat output  
Heating operation for a nominal  
heat output

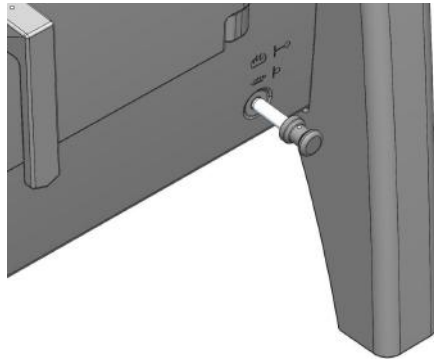

Closed  
Combustion air completely  
closed

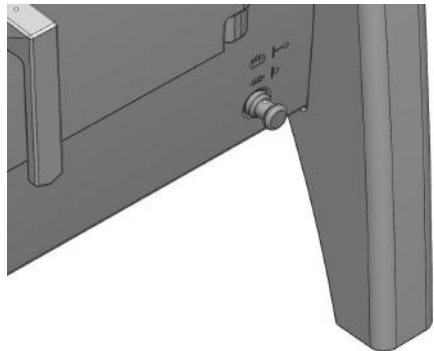

## **8.1 LIGHTING FIRE IN A COLD FIREPLACE**

- 1 Make sure that the level of ashes is not too high. Maximum level: 3 -5 cm below door frame. If the level of ashes is too high, glowing embers can fall out of the fireplace when stoking up wood.
- 2 Set the control element into position for lighting up. Combustion air can now stream intensively on the firewood for faster flaming up.
- 3 Load some chopped firewood loosely into the fireplace. Put a good fire-starter, such as Fidibus between the logs and light the fire. Fire-starters are practical fire starting aids, which should be placed under or in front of the wood. Please note: big logs are not easy to light and heavy to burn in a cold fireplace. Never use petrol or alcohol as aids for lighting fire!
- 4 Close the fireplace door and watch the burning flames for some minutes. If the fire goes out, open the door slowly, put a new fire-starter between the logs and light up again.
- 5 When the fire was lit successfully, the combustion air control element can be set to rated power position.
- 6 If you do not wish to stoke up more wood, move the control element into Glow position as soon as no flames are visible, to avoid temperature loss through unnecessary streaming of air into the fireplace. You cannot choose this control element position during combustion and degassing of wood, because this will cut off air completely and the fire goes out. In case of rapid air streaming from the room (when fireplace door is opened) it is possible that the gases "trapped" inside the combustion chamber and downstream radiators/accumulators will suddenly react with oxygen and explode (deflagration).

## 8.2 STOKING UP IN A WARM FIREPLACE

- 1 Move the combustion air control element into position for lighting up and put a desired amount of logs on the glowing embers. After wood is laid on the embers it gets warm, moisture is driven out and evaporates. This will reduce temperature of the combustion chamber. At the same time, the volatile particles driven out of wood will need a lot of air to pass through this critical phase and flame up fast to reach high temperature required for clean combustion.
- 2 When the fire is burning bright, the combustion air control element can be set to rated power position.
- 3 If you do not wish to stoke up more wood, move the control element into Glow position as soon as no flames are visible, to avoid temperature loss through unnecessary streaming of air into the fireplace. You cannot choose this control element position during combustion and degassing of wood, because this will cut off air completely and the fire goes out. In case of rapid air streaming from the room (when fireplace door is opened) it is possible that the gases “trapped” inside the combustion chamber and downstream radiators/accumulators will suddenly react with oxygen and explode (deflagration).

**Another hint:** Use always smaller pieces of wood for lighting up. These will flame up faster and cause temperature in the combustion chamber to increase. The bigger and thicker logs are better for stoking fire. Some sorts of wood briquettes can swell during combustion, i.e. they expand under heat and their volume increases. That kind of fuel must be placed always close to the back wall of combustion chamber, to prevent contact with glass door.

## 9 CLEANING

Once in a year, when the heating season begins, make sure to inspect the smoke pipe for ashes and residues. This should be possible through a revision provided on the installed fireplace insert. Remove the cleaning inlays from the hotplate and clean the ashes with a suitable vacuum cleaner.

When the fireplace was not used for a long time, call the chimney sweep to inspect and clean your chimney.

All cleaning operations must be carried out while the fireplace is cold –  
Risk of burns!

If the ceramic glass pane is only slightly stained, it can be cleaned with a dry cloth. Cleaning glass from dirty residues can be done easy with a piece of wet paper towel. Use it to pick some cold ashes from the combustion chamber of the fireplace. Clean the glass with this wet towel, then wipe the remaining wet ashes from the glass with a dry paper towel.



**Never use abrasive or aggressive cleaners!**



**Do not use brushes or any other mechanical means to clean sealing ropes!**

**During cleaning of glass, please protect the sealing ropes against getting wet.**

**Lifetime of sealing ropes will be significantly shorter, if they are soaked by fluids or cleaning agents.**

**Curing of the sealing rope can lead to glass breakage! Replace it when necessary!**

The fireplace needs always a thin bed of ashes to keep the glowing embers for longer. Do not clean the ashes completely, but always remove the “spare” cold ashes using a suitable vacuum cleaner (can be bought at your local stove dealer).



**Don't let the ashes rise above the top edge of fireclay bottom linings. The sealing ropes could get in contact with glowing embers and eventually burned.**

**Damage of sealing ropes arising from inappropriate operation or cleaning are excluded from warranty.**

Please follow the safety precautions regarding the handling of ashes and embers.

## 10 HINT

In order to guarantee a secure functioning of the **IRON DOG**, only original spare parts of the manufacturer may be used. Changes in the equipment may be accomplished exclusively through by the manufacturer authorized persons. The **IRON DOG** should be examined by your specialized enterprise regularly.

Non conform use of the equipment leads to expiring of the guarantee! The intended use of the equipment is guaranteed when the guidelines of the User Guide are observed.

## 11 ERROR SEARCH

### Error search

Possible cause	Background	Solution
Draught not available or not sufficient.	Outside temperature higher than indoor temperature, or the chimney cover on the roof is heated by the sun	Control chimney draught Warming-up fire in the chimney Wait until outside temperature is below indoor temperature
Fuel unsuited	Wood logs are to big Wood is damp or wet	Use dry and smaller wood

Possible cause	Background	Solution
Combustion air not sufficient	Without sufficient combustion air supply bad igniting and flow	Control push rod position (Start-up position) Control combustion air supply to the installation area Open fire door a little for a short time

### Fire burns weakly, much smoke, window becomes black

Possible cause	Background	Solution
Fuel unsuited	Wood logs are to big  Wood is damp or wet Fire chamber temperature too low	Only dry wood gives high ignition temperature with desired heat emission.
Combustion air not sufficient	Without sufficient combustion air supply bad igniting and flow.	Control the position of the push rod
Draught not available or not sufficient	Weather or the situation of the chimney influences the necessary exhaust of the gases.	Check the chimney draught in general  In case of important disturbance, change the chimney or install an exhaust gas extractor
	Creosote in or damage to the chimney reduces the necessary draught.	Clean the chimney and the connection pipes and examine them for tightness and damage.
	Check whether other stoves or fireplaces are connected to the chimney.	The chimney draught can be worsened by other connected fireplaces.

## 12 ATTENTION

We recommend that the **IRON DOG** should be installed and connected by a specialized enterprise, since security and proper functioning of the stove depend on an installation according to the rules. Actual standards and regulations must be observed.

IRON DOG - Partner:

Purchase date:

Ulrich Brunner GmbH

Zellhuber Ring 17-18

D-84307 Eggenfelden

Tel.: +49 (0) 8721/771-0

Fax: +49 (0) 8721/771-100

Email: [info@brunner.de](mailto:info@brunner.de)

**Art.No:**